



Y`



H



H



H





H



H



H





H

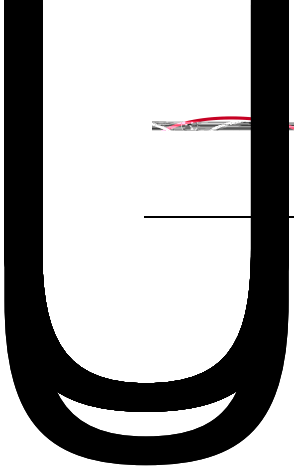

H

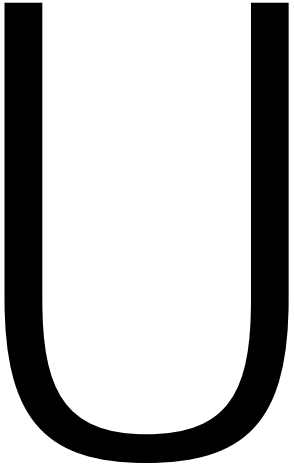

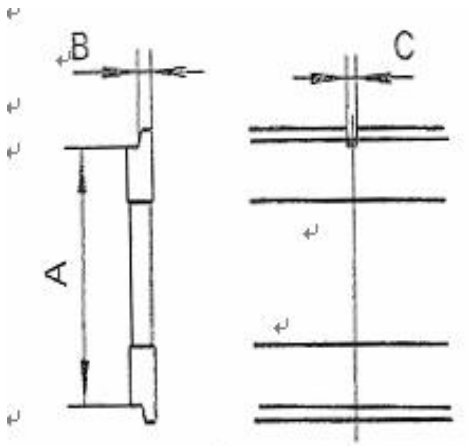



H



H





H





H



6.1



H
